

IMAGENEX MODEL 881L 6000 m DIGITAL MULTI-FREQUENCY IMAGING SONAR

APPLICATIONS:

- ROV, AUV, & UUV
- Offshore Oil & Gas
- Sunken Timber Recovery
- Diving Support
- Surveying
- Search & Recovery
- Inspection
- Underwater Archaeology
- Scientific Research

FEATURES:

- **Ethernet**
- Programmable
- Multi-frequency
- High performance
- Lower cost
- Low power
- Simple set-up and installation
- Digital telemetry
- Full scale range from 1 m to 200 m
- Compact size
- Communication format available to user

Using Ethernet communications, this all-in-one, high performance digital imaging sonar can exceed 100 shots per second on the 1 m range at a 2 mm range resolution, producing near-photographic image quality.

The 881L is a multi-frequency system that can operate with customized configurations or revert to default settings to match appropriate operating range scales.

In addition to the benefits of low power, a simple set-up and installation procedure make this powerful sonar an ideal tool for remotely operated platforms ranging from large work ROV's to small inspection vehicles, as well as AUV and UUV applications.

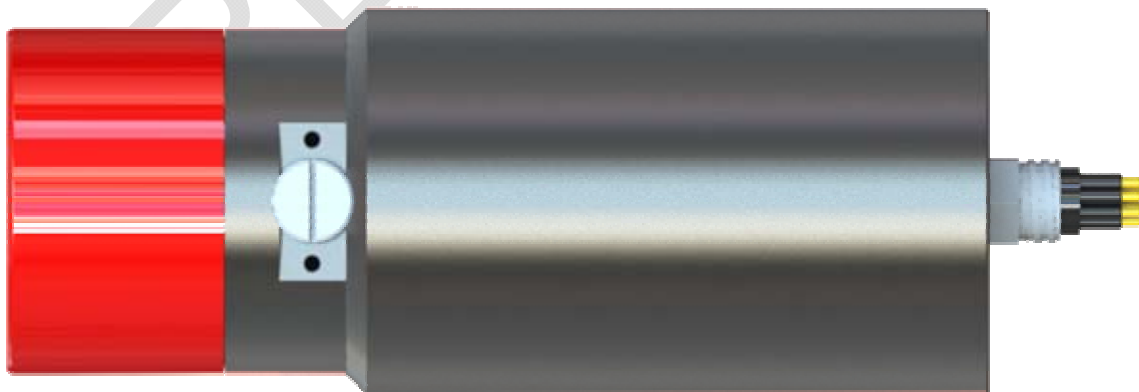

HARDWARE SPECIFICATIONS:	
FREQUENCY	310 kHz, 675 kHz, or 1 MHz (default settings) -Other frequencies can be selected through programmable software configurations (Tunable from 280 kHz to 1.1 MHz in 5 kHz steps)
TRANSDUCER	Imaging type, fluid compensated
TRANSDUCER BEAM WIDTH	310 kHz: 4° x 40° 675 kHz: 1.8° x 20° 1 MHz: 0.9° x 10°
RANGE RESOLUTION	1 m – 4 m: 2 mm (0.08") 5 m & up: 10 mm (0.4")
MIN. DETECTABLE RANGE	150 mm (6")
MAX. OPERATING DEPTH	6000 m
MAX. CABLE LENGTH	Standard: 100 m on CAT5e Cable length may be increased up to ~9000 m using an Ethernet extender. Please enquire for more information.
INTERFACE	Standard: 10 Mbps Ethernet (10 BASE-T) using TCP/IP Bit rate may vary if an Ethernet extender is in use.
CONNECTOR	Side mounted, eight conductor, wet mateable (Subconn MCBH4M-Ti) Optional right angle or end mount connector
POWER SUPPLY	20 – 36 VDC at less than 5 Watts
DIMENSIONS	88.9 mm (3.5") diameter x 225 mm (8.85") length
WEIGHT: In Air	~3.1 kg (6.8 lbs)
In Water	~1.8 kg (3.9 lbs)
MATERIALS	Titanium & Polyurethane
FINISH	None

SOFTWARE SPECIFICATIONS:	Win881L.exe, Win881AL.exe
WINDOWS™ OPERATING SYSTEM	Windows™ XP, Vista, 7, 8, 10
MODES	Sector, Polar and Side Scan
RANGE SCALES	1 m, 2 m, 3 m, 4 m, 5 m, 10 m, 20 m, 30 m, 40 m, 50 m, 60 m, 80 m, 100 m, 150 m, 200 m
TRAIN ANGLES	Continuous rotation, 3° increments
SECTOR SIZE:	
SECTOR MODE	0° – 180°, 3° increments
POLAR MODE	0° – 357°, 3° increments, or Continuous rotation
STEP SIZES	Slow (0.3°), Medium (0.6°), Fast (0.9°), Faster (1.2°), Fastest (2.4°)
GRID TYPES	Polar and rectangular
FILE FORMAT	(filename).81L
RECOMMENDED MINIMUM COMPUTER REQUIREMENTS:	100 MHz Pentium 16 MB RAM 1 GB Hard Disk 800 x 600 x 256 colour graphics

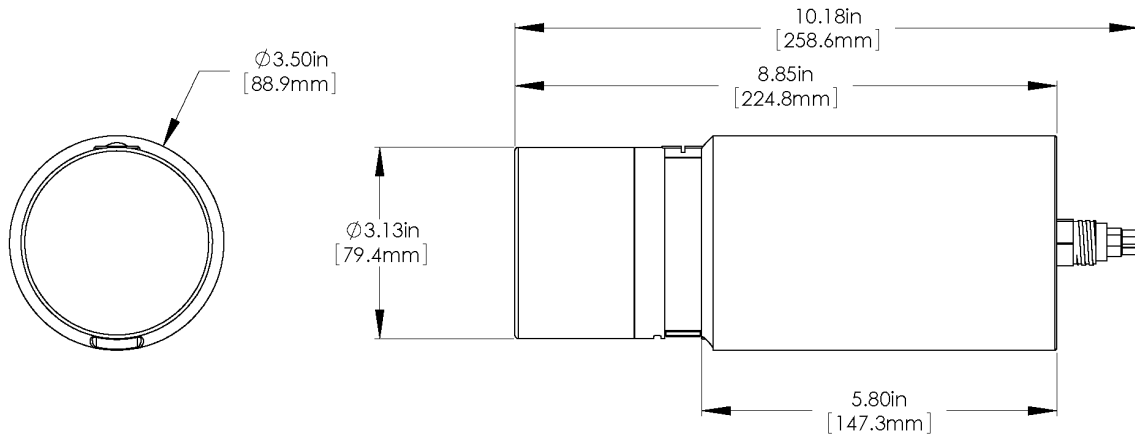

ORDERING INFORMATION:		
6000 m UNIT	Standard	881-000-502
End mount connector	Option	-009
Right angle connector	Option	-010
IP Address*	Option	-020

*Note: Standard IP Address is 192.168.0.5
 A different IP Address may be specified upon ordering.

Product and company names listed are trademarks or trade names of their respective companies.