



IMAGENEX MODEL 882-GS GYRO STABILIZED MULTI-FREQUENCY IMAGING SONAR

APPLICATIONS:

- ROV, AUV, & UUV
- Manned Submersibles
- Search & Recovery
- Borehole/cave work
- Drop sonar
- Scientific Research

FEATURES:

- **Ethernet** (or Optional Serial)
- Programmable (format available)
- Gyro stabilized transducer steering
- Simple set-up and installation
- Full scale range from 1 m to 100 m
- Orientation module

Gyro-stabilization makes the high resolution 882-GS sonar capable of crystal clear visualization of the ocean environment from moving platforms, no longer compromised by the blurring effects of host vehicle rotation. An advanced, low drift gyro is integrated directly into the sonar head, so the sonar can compensate for vehicle motion in real time with unprecedented accuracy, stability, and robustness.

Using Ethernet communications, this all-in-one, high performance digital imaging sonar exceeds 100 shots per second on short range at up to 2 mm range resolution, and can auto-adjust acoustic frequency and resolution to scan up to a 100 m radius, 360° surrounding area.

The Model 882-GS has low power, simple set-up, and small size that make it an ideal tool for large work ROV's and small inspection vehicles. On it's own it is an amazingly simple drop sonar and borehole inspection package: just add a laptop computer and power supply and run the included Imagenex software.



HARDWARE SPECIFICATIONS:	
FREQUENCY	675 kHz or 1 MHz (standard default settings) -Other frequencies can be selected through programmable software configurations (Tunable from 280 kHz to 1.1 MHz in 5 kHz steps)
TRANSDUCER	Imaging type, fluid compensated
TRANSDUCER BEAM WIDTH	675 kHz: 1.8° x 20° 1 MHz: 0.9° x 10°
RANGE RESOLUTION	1 m – 4 m: 2 mm (0.08") 5 m & up: 10 mm (0.4")
ORIENTATION MODULE (accuracies):	
PITCH & ROLL	± 0.1° typical
HEADING (Magnetic)	± 1.0° typical
MIN. DETECTABLE RANGE	150 mm (6")
MAX. OPERATING DEPTH	300 m and 1000 m available
MAX. CABLE LENGTH	Standard: 100 m on CAT5e (Ethernet) Cable length may be increased up to ~9000 m using an Ethernet extender. Please enquire for more information.
(Optional Serial Interface)	1000 m on typical twisted shielded pair (RS-485)
INTERFACE	Standard: 10 Mbps Ethernet (10 BASE-T) using TCP/IP Bit rate may vary if an Ethernet extender is in use.
(Optional Serial Interface)	RS-485 serial interface @ 115.2 kbps (or optional RS-232)
CONNECTOR	Ethernet IE55-1206-BCR
	Serial IE55-1004-BCR
POWER SUPPLY	20 – 32 VDC at less than 7 Watts
DIMENSIONS	300 m unit: See drawing below 1000 m unit: TBA
WEIGHT: In Air	300 m unit: ~1.2 kg (~2.6 lbs) 1000 m unit: TBA
In Water	300 m unit: ~0.3 kg (~0.7 lbs) 1000 m unit: TBA
MATERIALS	6061-T6 Aluminum & Polyurethane
FINISH	Hard Anodize

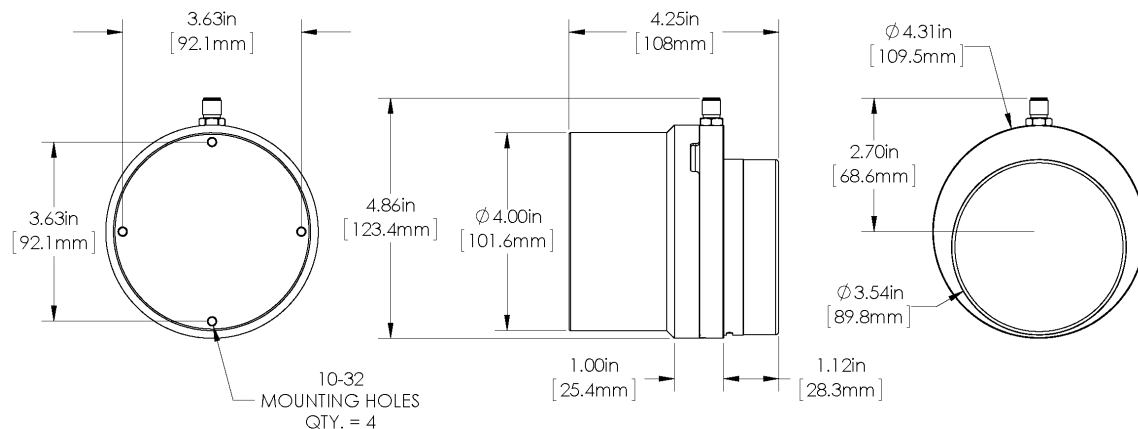

SOFTWARE SPECIFICATIONS:	Win881AL.exe
WINDOWS™ OPERATING SYSTEM	Windows™ XP, Vista, 7, 8, 10
MODES	Sector, Polar and Side Scan
GYRO MODES	North Up, Heading Up, Target Steering
RANGE SCALES	1 m, 2 m, 3 m, 4 m, 5 m, 10 m, 20 m, 30 m, 40 m, 50 m, 60 m, 80 m, 100 m
TRAIN ANGLES	Continuous rotation, 3° increments
SECTOR SIZE: SECTOR MODE POLAR MODE	0° – 180°, 3° increments 0° – 357°, 3° increments, or Continuous rotation
STEP SIZES	Slow (0.3°), Medium (0.6°), Fast (0.9°), Faster (1.2°), Fastest (2.4°)
GRID TYPES	Polar and rectangular
FILE FORMAT	(filename).81R
RECOMMENDED MINIMUM COMPUTER REQUIREMENTS:	2 GHz Pentium 4 256 MB RAM 20 GB Hard Disk 1024 x 768 Screen Resolution

ORDERING INFORMATION:		
300 m UNIT	Standard	882-000-100
1000 m UNIT	Standard	882-000-101
RS-232	Option	-006
RS-485	Option	-007
IP Address* (for Ethernet version only)	Option	-020

*Note: Standard IP Address is 192.168.0.5
A different IP Address may be specified upon ordering.

Product and company names listed are trademarks or trade names of their respective companies.

I M A G E N E X

IMAGENEX TECHNOLOGY CORP.

**Model 882A
Gyro Stabilized Scanning Sonar**

(Serial Version)

Quick Start

Number	430 - 033	
Revision	Date	Description
00	September 24, 2014	Release
02	January 22, 2015	Added auto bias, and auto file size

Table of Contents

1.0 Introduction.....	1
2.0 Getting Started:.....	1
2.1 Step-By-Step Start Up Guide.....	1
2.2 Gyro Calibration.....	2
2.2.1 Manual Gyro Calibration procedure.....	2
2.3 Overview.....	3
2.4 Hardware.....	5
2.5 Software.....	6
2.5.1 Acquire Target.....	8
2.5.2 Latitude Adjustment and Compass Declination.....	11
2.5.3 File Size Limits.....	11
Appendix A – USB Data Converters and Windows XP.....	12
A.1 - Virtual Communication Ports.....	12
A.2 - Common Windows© Issues related to all USB <--> Serial Converters.....	13
A.3 - Determining the Assigned Com Port For All USB <--> Serial Converters.....	14

Table of Figures

Figure 2.1: Unstabilized Image.....	3
Figure 2.2: Stabilized Image.....	4
Figure 2.3: 882A.....	5
Figure 2.4: Options Menu.....	6
Figure 2.5: Standard 882A Display.....	7
Figure 2.6: Acquire Target button has been selected.....	9
Figure 2.7: Target has been selected.....	10
Figure 2.8: Auto File Sizes.....	11
Figure 1 : Overview of USB Data Converter Logic Flow.....	12
Figure 2 : System Properties.....	14
Figure 3 : System Properties - Select Hardware Tab.....	15
Figure 4 : Device Manager – Select Ports and double click device.....	15
Figure 5 : Port Properties – Select “Port Settings”.....	16
Figure 6 : Port Properties - Click "Advanced".....	16
Figure 7 : Advanced Port Properties - Select Com Port Number.....	17
Figure 8 : Creating a Device Manager Shortcut.....	17

Index of Tables

Table 2.1: Options Menu.....	6
Table 2.2: Main Display.....	8
Table 1 : Windows Com Port Assignment Scheme.....	13

1.0 Introduction

The Model 882A is an advanced gyro-stabilized, high-resolution scanning sonar system that has been designed to provide simple, reliable, and accurate representation of underwater images.

2.0 Getting Started:

The 882A was designed to be user friendly and simple to set up in the field. It is generally recommended however to perform a preliminary setup before heading out into the field.

2.1 Step-By-Step Start Up Guide

1. Physically mount the sonar referring to **Section 2.4** on **page 5** for details.
2. Ensure 24V_{DC}@ 2A minimum power supply is off
3. Connect the DB9 to the PC's RS485 card or via a USB-RS485 adaptor.
4. Plug the underwater connector to the sonar.
5. Deploy to stable, flat location
6. Power up the 882A.
7. Wait for gyro calibration to complete. The sonar, upon power up, will calibrate the motor, and automatically perform a gyro calibration. No communication to the gyro sub system is available at this time.
8. Verify the “**Local Latitude**” setting in the “.ini” file and adjust if necessary. Refer to **Section 2.5.2** on **page 11** for details
9. Launch the “*Win881AL_GS.exe*” program
 - If file playback is desired, use the menu command “*File->Open File to Playback*”.
 - If real-time operation is desired, use the menu command “*File->Connect to Sonar Head*”.
10. Proceed to **Section 2.5** on **page 6** for software instructions.

2.2 Gyro Calibration

Imagenex Gyro enabled scanning sonars now incorporate an automatic gyro biasing feature which is selectable in the program. This mode continuously re-bias's the gyro in real time accommodating for temperature fluctuations. Refer to Table 2.1 on page 6 for details on enabling / disabling this mode. The information below describes the manual biasing mode which may be necessary in strong magnetic field environments.

All gyros are sensitive to the environment (i.e. temperature, motion, Earth's rotation, etc.) and will naturally drift with time. Therefore, from time to time, it is recommended to issue a gyro calibration to remove the accumulated drift.

It is **ESSENTIAL** that the sonar is completely stationary and at constant temperature during gyro calibration. **ANY** movement will cause undesirable drift in the gyro.

2.2.1 Manual Gyro Calibration procedure

Do not calibrate the gyro until the internal temperature of the sonar has stabilized, approximately 30-60minutes underwater.

1. Mount sonar on a level, stable surface, or settle the ROV on a flat bottom.
2. Under the “Options” Menu, select “Calibrate Gyro”.
3. Standard sonar operation is suspended during gyro calibration.
4. The message “Calibrating Gyro” will appear. Calibration takes approximately 30secs.
5. Once the message disappears, standard operation commences.

2.3 Overview

While traditional scanning sonars provide excellent imagery, they have a significant short coming...they rely on the sonar being perfectly still during data acquisition. Imagenex has developed the ideal solution...the 882A. Figure 2.1, below, shows a non stabilized image taken while the sonar was spinning. Note the wavy lines in the lower 2 quadrants. Now refer to the same area scanned with Gyro stabilization enabled (Figure 2.2, below). Now the image is well defined and straight.

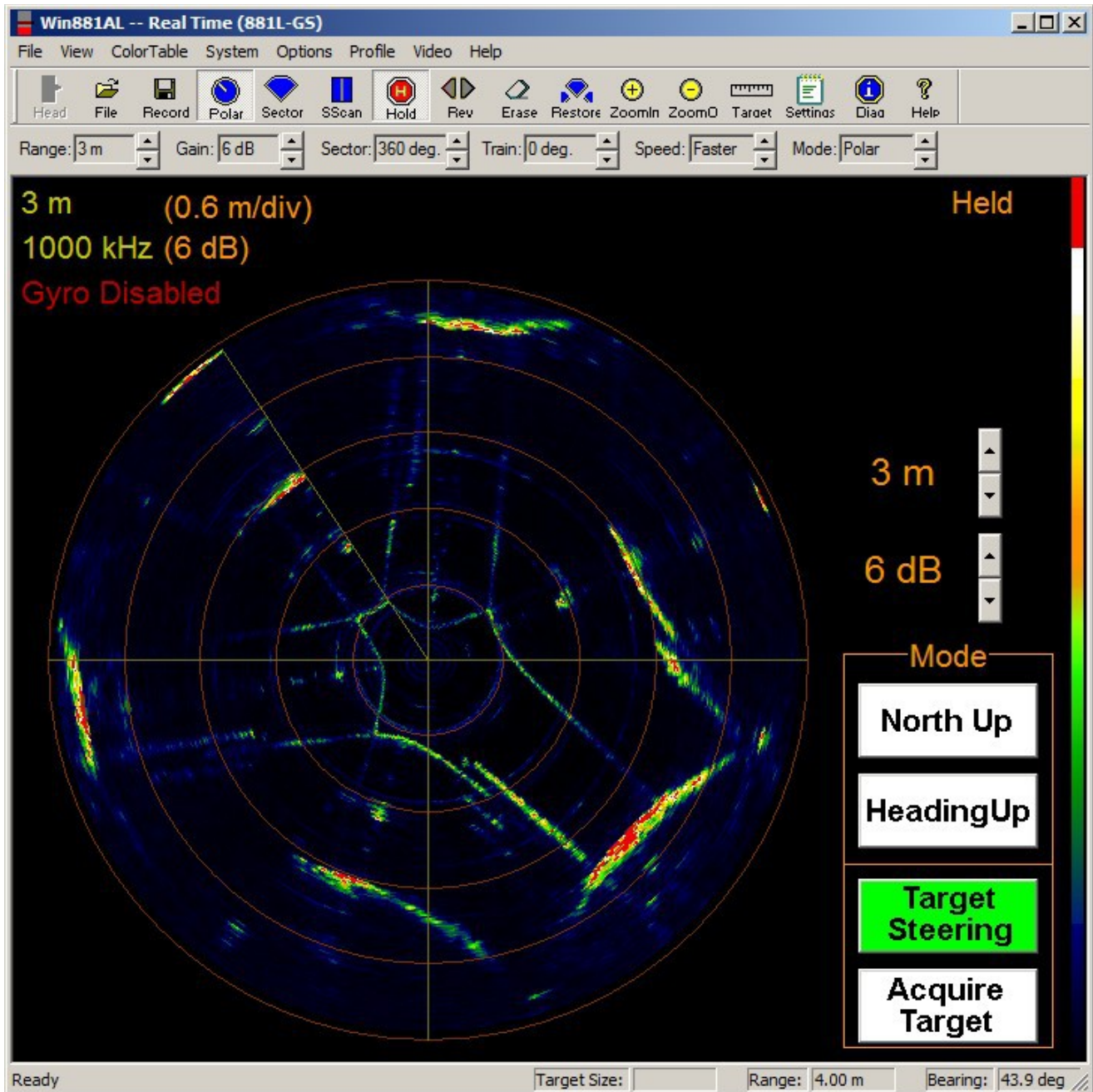

Figure 2.1: Unstabilized Image

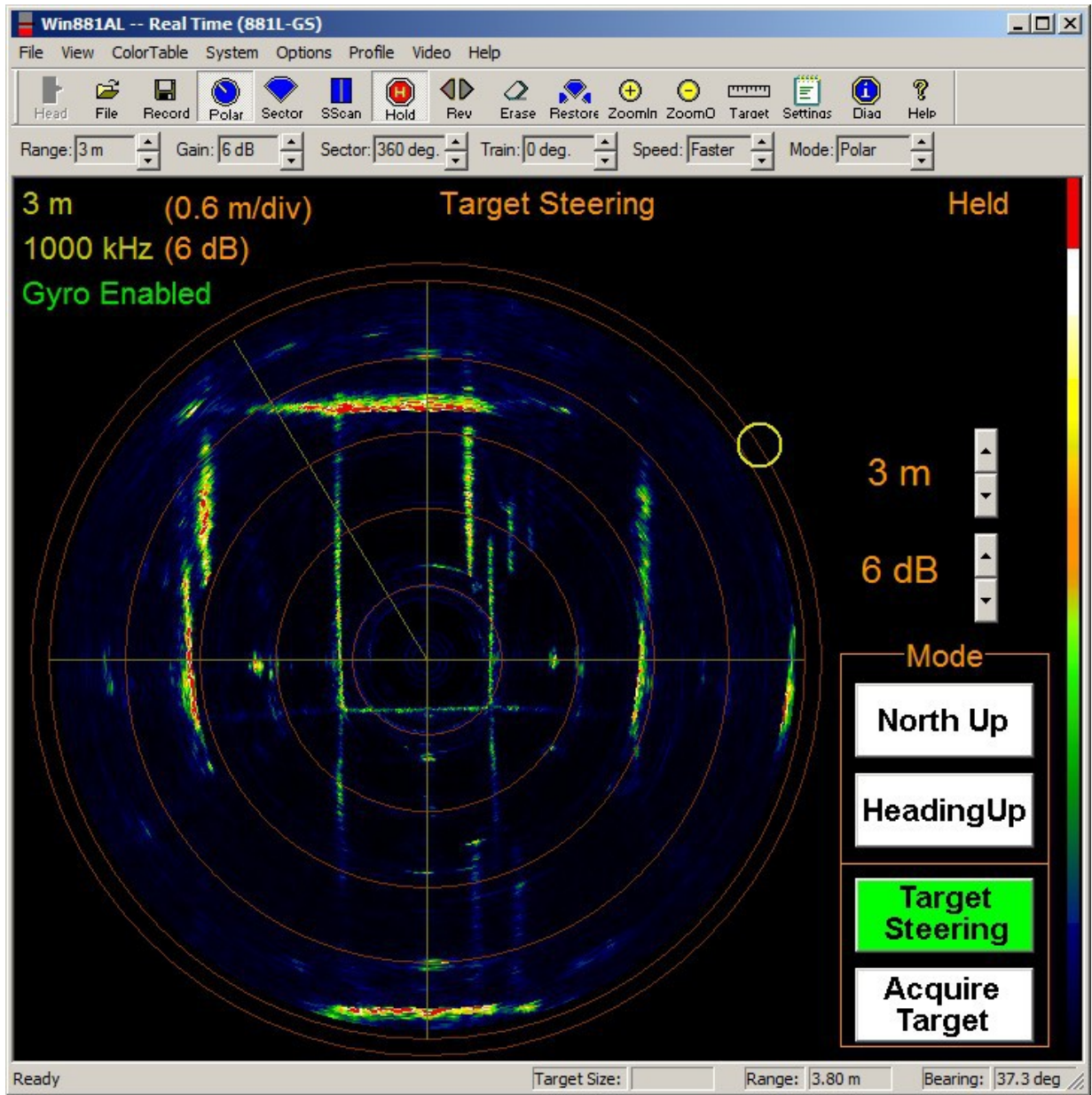

Figure 2.2: Stabilized Image

2.4 Hardware

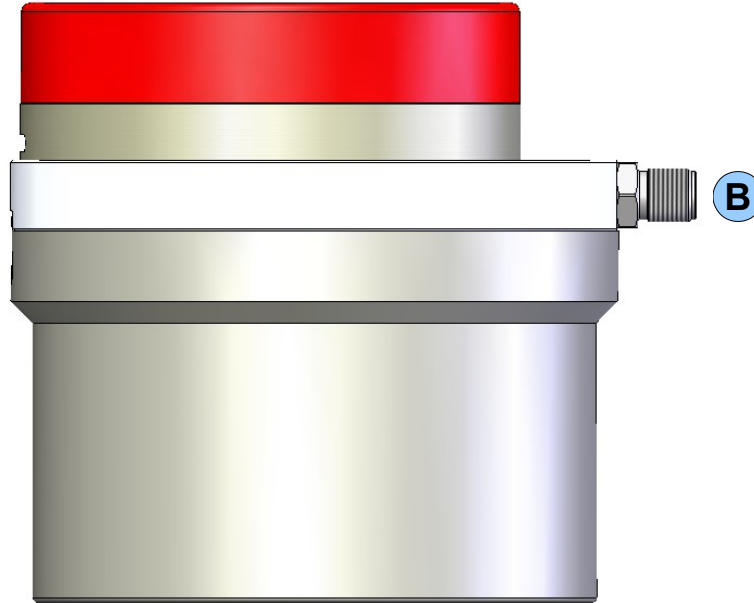

Figure 2.3: 882A

Figure 2.3, above, indicates the 882A in the “Transducer Up” orientation.

- A** Transducer End. **FRAGILE**. This area **MUST** be exposed to the water with no obstruction. Do not mount sonar using this area.
- B** Connect sonar cable. Ensure locking sleeve is used. Do not bend pins.
- C** Electronics Bottle. Use this area for mounting the sonar.

2.5 Software

After installing the “Win881AL_GS.exe” program (generally “C:\Program Files (x86)\Imagenex”), load the program by double-clicking on its icon.

The program, which supports the 881A, 881L, 881A-GS, 881L-GS, 882L, and 882A will need to be told which sonar type is being connected. Choose 882A from:

“System => Sonar Type => 882A”

This configures the program to operate in 882A mode.

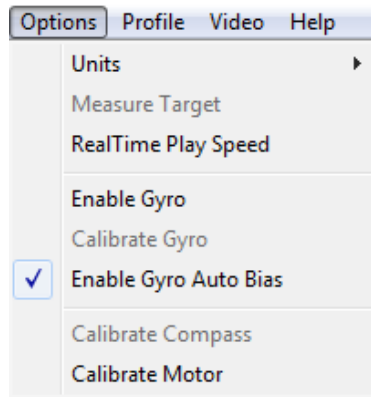

Figure 2.4: Options Menu

Ref	Item	Description
1	Enable Gyro	Enables Gyro Stabilized Image. Deselect to operate as standard scanning sonar.
2	Calibrate Gyro	Calibrates gyro to compensate for drift.
3	Enable Gyro Auto Bias	Enabling this puts the sonar into auto bias mode where the sonar will continuously re-bias the gyro in real time. Disabling this mode requires a manual bias as described in Section 2.2.1 on page 2.
4	Calibrate Compass	Field Calibrates the internal Compass. To calibrate the compass, the sonar head MUST be rotated 360° (direction is irrelevant). Check “Calibrate Compass”, rotate 360°, then un-check “Calibrate Compass” to store the settings.
5	Calibrate Motor	Calibrates Motor and realigns the sonar head position relative to the transducer position.

Table 2.1: Options Menu

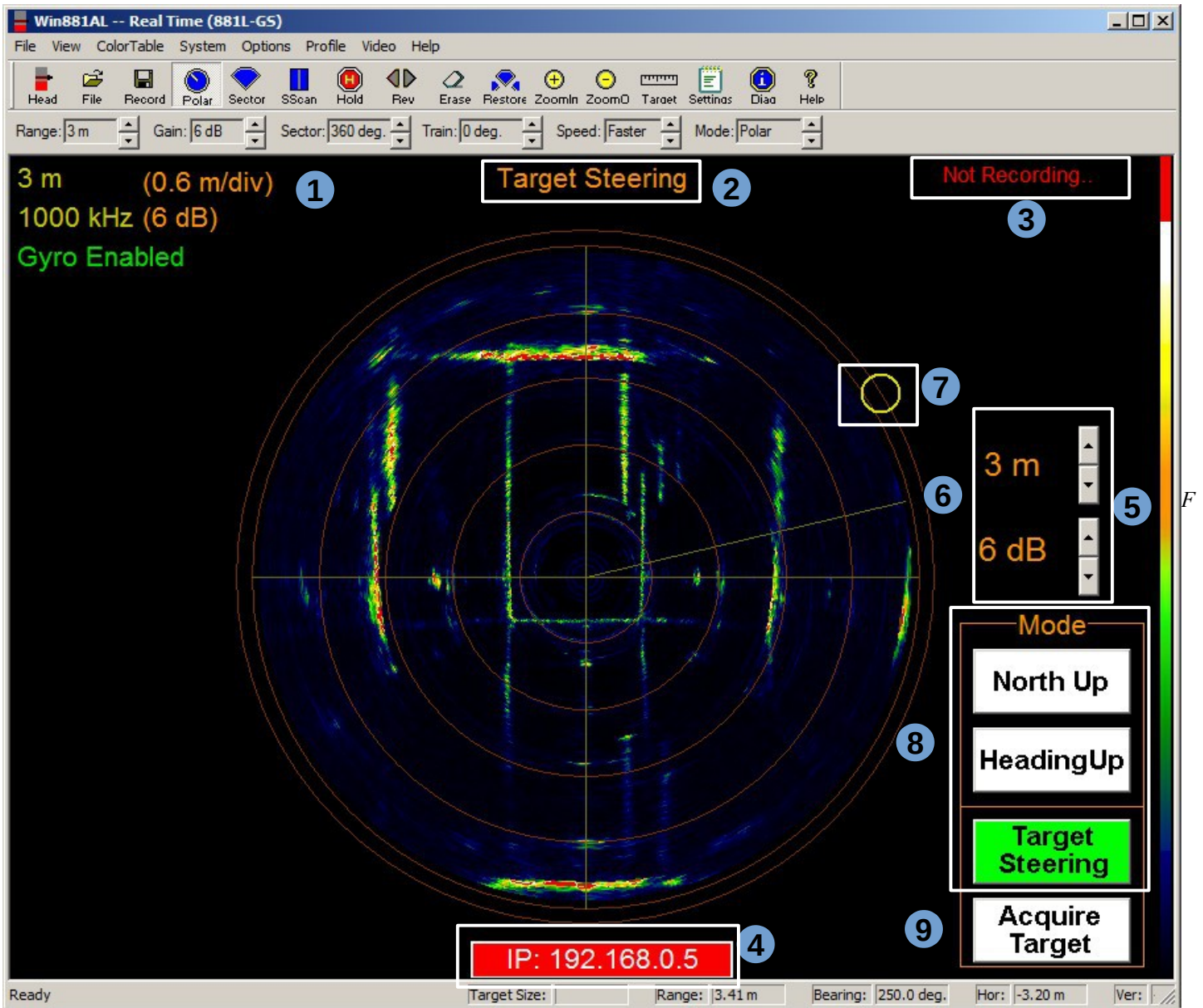

figure 2 5: Standard 882A Display

Ref	Item	Description
1	Range / Frequency Display	Display current acoustic range and frequency of sonar in yellow. Displays Grid scale and current gain in orange
2	Gyro stabilized operating mode	Displays only when Gyro Stabilized Image is enabled. One of: North Up, Heading Up, or Target Steering.
3	File Recording information	Displays “Not Recording” or “Recording...”
4	Communication Error Status	Displays “No Connection” when communication to the sonar is interrupted.
5	Quick Setting	Quick Setting for sonar range and gain
6	Wiper	Current transducer position for the “ping”
7	Sonar Position Indicator	The yellow circle indicates the current sonar position independent of the transducer position. In North Up mode, the circle will transverse around the perimeter of the sonar image which remains stationary in a North up orientation. In Heading Up mode, the circle will remain stationary at the top of the screen, while the sonar image rotates. In Target Steering mode, the circle will transverse around the perimeter of the sonar image which remains stationary
8	Gyro Stabilized Image mode selection	Selects the various modes of display. In North Up mode, the circle will transverse around the perimeter of the sonar image which remains stationary in a North up orientation. In Heading Up mode, the circle will remain stationary at the top of the screen, while the sonar image rotates according to the heading. In Target Steering mode, the circle will transverse around the perimeter of the sonar image which remains stationary
9	Acquire Target	Only active in “Target Steering mode, “Acquire Target” allow the user to select a target location. The sector will then be centred on the selected target and rotated to place the target at the top of the display. See Section 2.5.1, below for details.

Table 2.2: Main Display

2.5.1 Acquire Target

The 882A has the ability to select a target of interest, and automatically centre and scan that target on screen. The procedure is as follows.

1. Ensure the gyro is enabled and in “Target Steering” mode.
2. Select the button “Acquire Target”.
3. Select desired target on screen

The image will perform a full polar scan.

The mouse cursor will change to 

The screen will automatically change to a top sector view with the target centred within the sector

This is described further below.

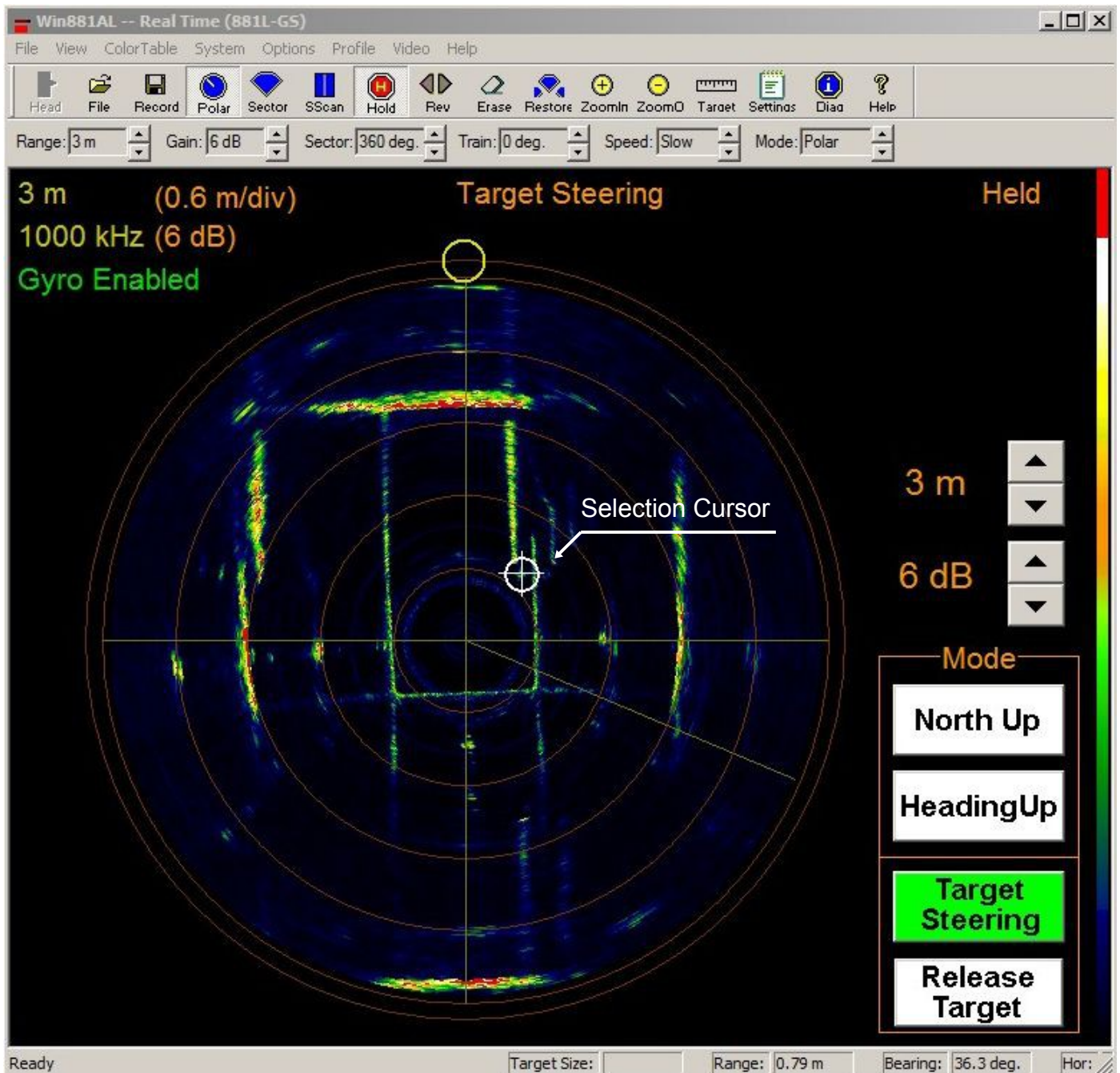



Figure 2.6: Acquire Target button has been selected

In Figure 2.6, above, the “Acquire Target” was selected and the mouse cursor changed to . In this example, the target of interest is positioned under the target cursor.

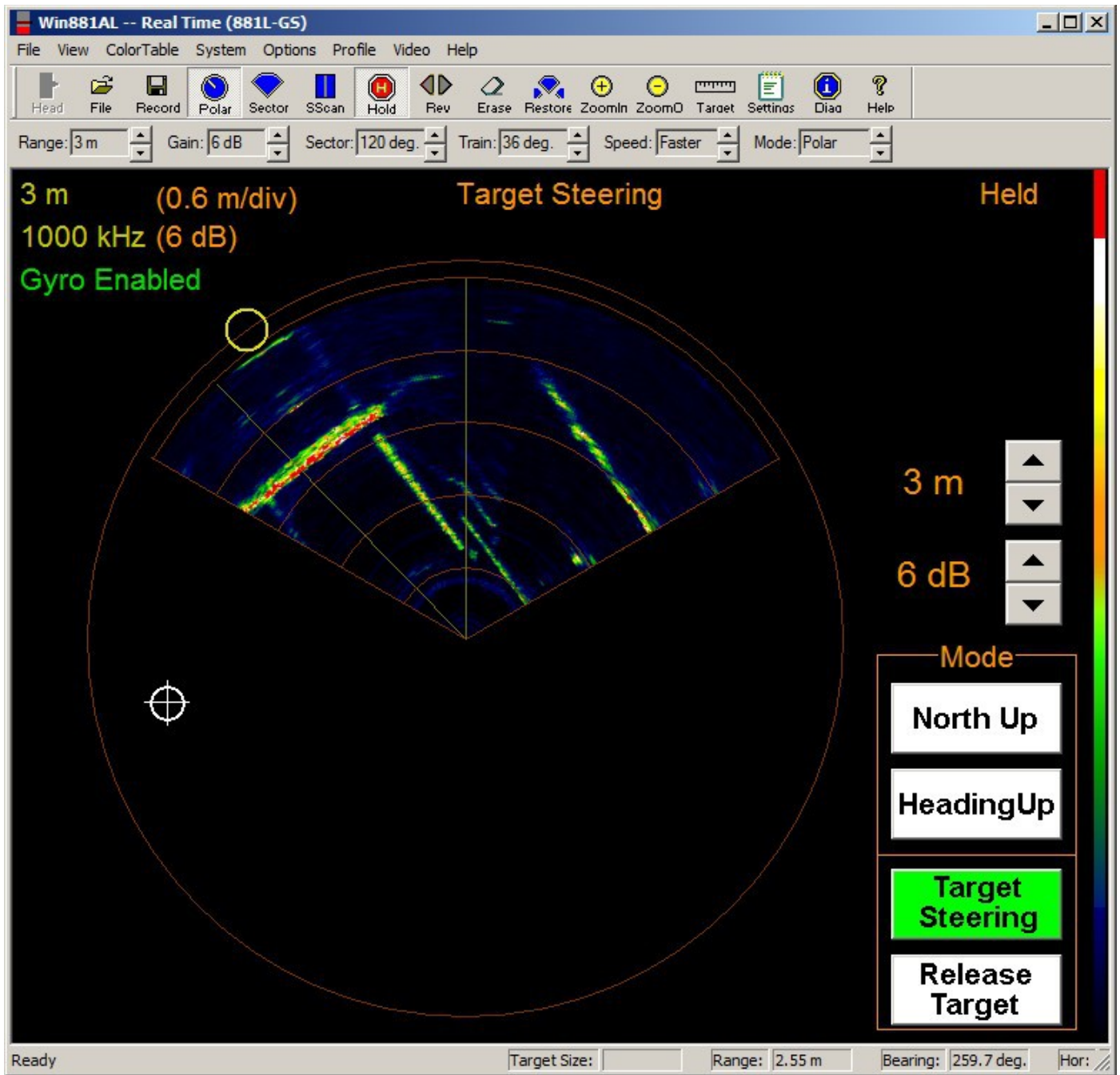

Figure 2.7: Target has been selected

In Figure 2.7, above, the desired target from Figure 2.6 was selected. The screen automatically centred the target within a sector and rotated the sector to the top of the screen. The sonar will now scan the sector with the centred target.

To return, select “Release Target” to remove the sector restrictions and train angle.

2.5.2 Latitude Adjustment and Compass Declination

The geographical local latitude compensates for drift caused by the Earth's rotation. To set the latitude of the current location, open the file "*Win881AL.ini*" in a text editor and edit the lines:

- Local Latitude=49.250000 → (0 to 90 for northern latitudes, 0 to -90 for southern latitudes)
- CompassDeclination=16.5 → ($\pm 180^\circ$, offset to Magnetic North. West is negative, East is positive).

To match the approximate location of the sonar.

Once these are set, run the "*Win881AL_GS.exe*" program as per usual.

Initiate a Gyro Calibration once the sonar is operating.

The "Local Latitude" will not take effect until a "**CALIBRATE GYRO**" command is initiated manually under the "*Options*" menu.

The compass declination angle is used for displaying the sonar image referenced to True North rather than Magnetic North.

The default values are for Vancouver, BC, Canada which has a latitude of 49.25° North and a magnetic compass declination of 16.5° (as of 2014).

2.5.3 File Size Limits

Storing video can generate very large files, The software is able to automatically split the recorded file in predefined file sizes as shown below in Figure 2.8

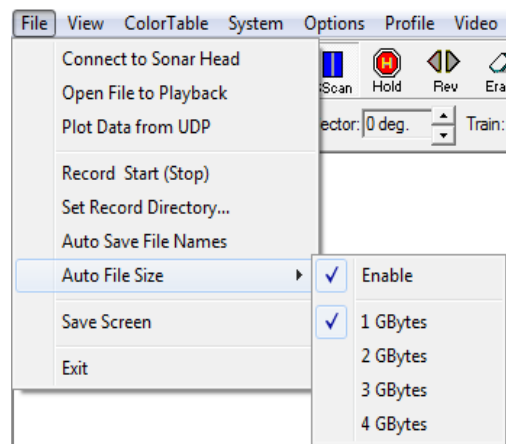

Figure 2.8: Auto File Sizes

In order to re-join two split files, from the command prompt type:

```
copy /b "Source1.81R"+"Source2.81R" "dest.81R"
```

without the quotes.

Appendix A – USB Data Converters and Windows XP

With the proliferation of the “*Universal Serial Bus*” (USB) compatible devices available for notebook and desktop computers, manufacturers are rapidly omitting physical serial ports on their products in order to cut production costs. The USB bus is extremely versatile as there are no Com Port conflicts, no IRQ's to deal with, and has support for up to 256 devices on one bus (while there are usually multiple USB ports on a computer, there are usually only two physical USB buses).

With all that is going for it, one would wonder why use serial devices at all. Good question. Major factors in retaining a true physical serial device are:

Cable length – USB has a maximum cable length support of 5m (~16')

Latency – USB is a packet driven technology and as such delays occur due to USB driver packaging schemes.

A.1 - Virtual Communication Ports

To get a serial device (RS-232 or RS-485) connected to a computer that only has USB ports, a converter needs to be installed in-line between the USB port and the serial device. These converters install a special driver in Windows called a “Virtual Com Port”. This software will emulate a serial port so that serial enabled software can simply “see” the USB port as a serial port. See the figure below for an overview.

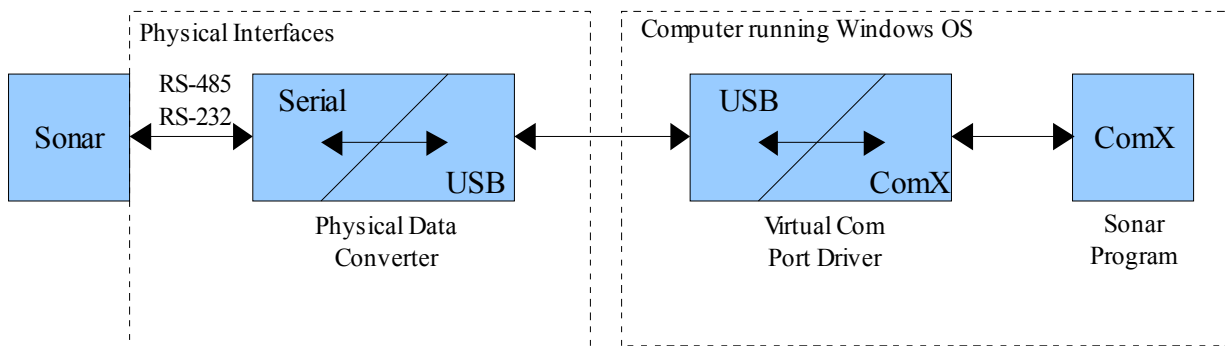

Figure 1 : Overview of USB Data Converter Logic Flow

One caveat is that Windows can get “confused” if a device is plugged into a USB port while there is data being transmitted through it. Windows thinks that the device is a “pen mouse” and the mouse cursor will behave erratically. If this happens, the computer will need to be restarted. To circumvent this phenomena, **DO NOT** connect GPS, or other devices to the USB adapter until the adapter is fully functional (i.e. plug the converter into the computer and wait until Windows sets it up and assigns it a Com Port number **BEFORE** plugging a serial device into the converter).

Generally, once a converter is correctly installed, Windows will assign a Com Port number to **A PARTICULAR** device on **A PARTICULAR** USB port. Once this is done, things run pretty smoothly....until the operator changes something....

A.2 - Common Windows® Issues related to all USB <--> Serial Converters

This section is directed towards a USB device that is encoded with a serial number. If the USB is not encoded with a serial number, Windows will not assign a different Com Port number for each device. It will still, however, assign a different Com Port number for each physical USB port.

Windows XP will assign a Com Port number to a USB device when it is first installed in the system. However, it will assign a **DIFFERENT Com Port** number to the same device when it is plugged into a **DIFFERENT USB port** on the same computer. To further complicate matters, Windows XP will assign a **DIFFERENT Com Port** number to a **DIFFERENT** device when it is plugged into the **SAME USB port** on the same computer.

Table 1 : Windows Com Port Assignment Scheme

Converter	USB Port	Assigned Com Port
A	A	4
A	B	5
A	A	4
B	A	5

The table above indicates a possible scenario where various converters are plugged into various USB ports. The assigned Com Port numbers above are only for illustration purposes. Windows will actually assign the device the next available Com number.

For example, If you first plug the device into the BACK USB port of the laptop, Windows will assign it a Com Port number of (for arguments sake) '4' When you start the DeltaT software, you set the GPS Com Port to '4', and it runs fine. The next time you use the device, you plug the same device into the SIDE USB port on the laptop. Windows will then assign the device a Com Port number of (again, for arguments sake) '5'. Now when you start the DeltaT software, it cannot open, or find, Com Port '4' as the device is now set to Com Port '5'. You set the Com Port in DeltaT to '5' and it again runs fine.

There is no solution for this behaviour. It is a Windows function, and Imagenex has no control as to how the Com Ports are assigned to a device.

Our suggestion is to only use the same USB port for each device. For example, only use the BACK USB port for GPS input.

Also, if a different serial device is plugged into the same USB port, Windows will assign it a different Com Port again. For example, if Com Ports '4' and '5' are already taken, Windows will assign it Com Port '6'.

To make a long story short. Windows assigns a specific Com Port to a specific serial device plugged into a specific USB port. If any combination changes, Windows will assign a different Com Port.

A.3 - Determining the Assigned Com Port For All USB <--> Serial Converters

This section describes various procedures for determining the assigned Com Port of a converter. This document assumes the Windows XP Pro operating system and other computers may appear differently. However, the procedures will be similar regardless of the Windows version.

To access the Device Manager from the Desktop:

1. Right click on “My Computer”
2. Left click “Properties”
3. Follow the following Illustrations to Set the Com Port Number of the Device. Note that these Illustrations are for the ATEN UC-232A Device. Also, Ignore the baud rate settings. Imagenex software automatically opens the port at the correct parameters.

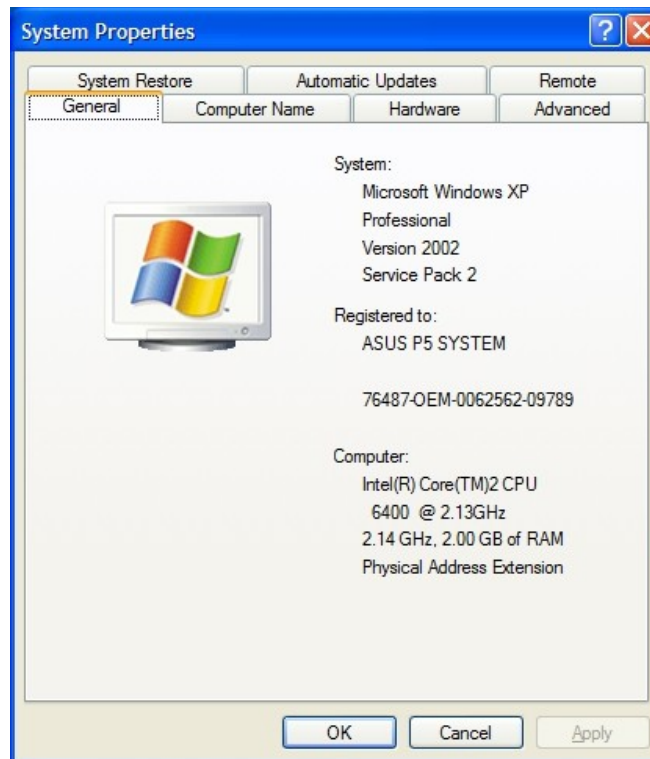

Figure 2 : System Properties



Figure 3 : System Properties - Select Hardware Tab

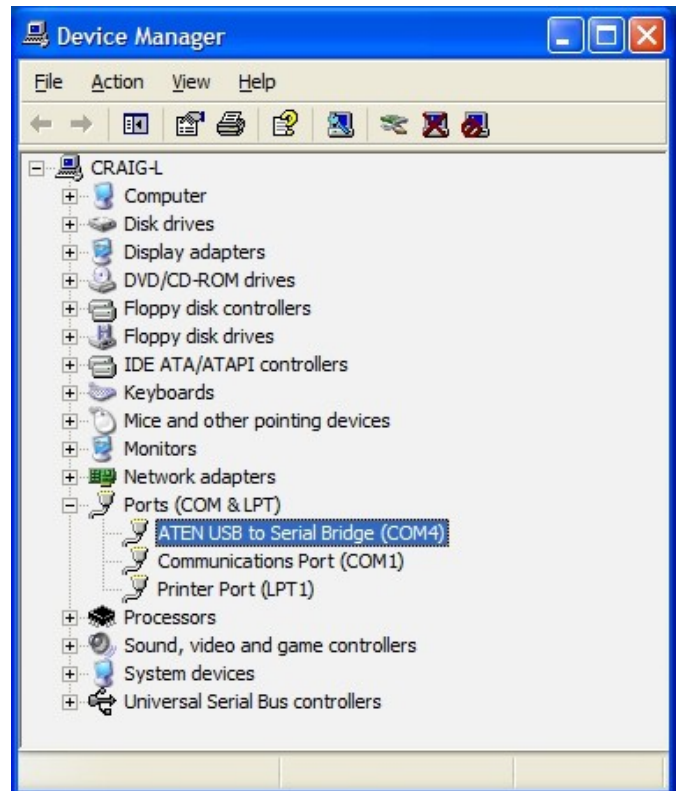

Figure 4 : Device Manager – Select Ports and double click device



Figure 5 : Port Properties – Select “Port Settings”

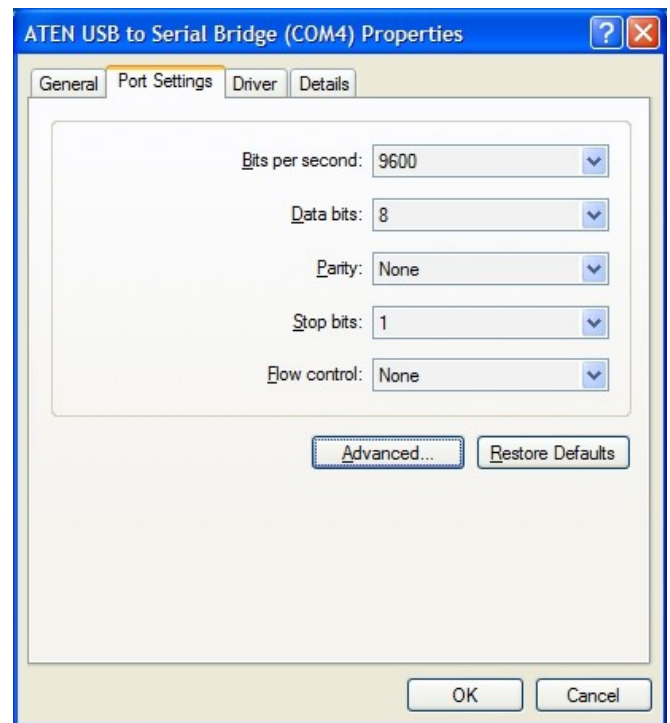

Figure 6 : Port Properties - Click "Advanced"

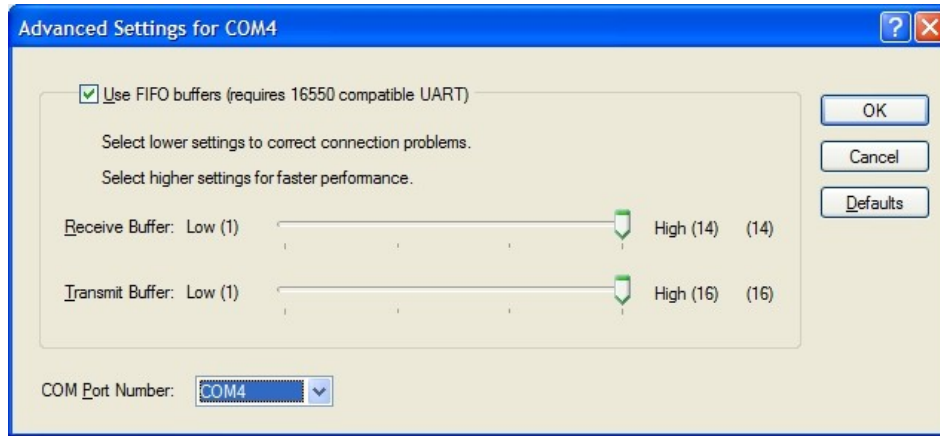

Figure 7 : Advanced Port Properties - Select Com Port Number

Quick Tip

To make a shortcut to the Device Manager on the Windows desktop:

1. Right click on the Windows desktop
2. Select “New” --> Shortcut
3. Enter “devmgmt.msc”
4. Select “Next”
5. Enter “Device Manager”
6. Select Finish

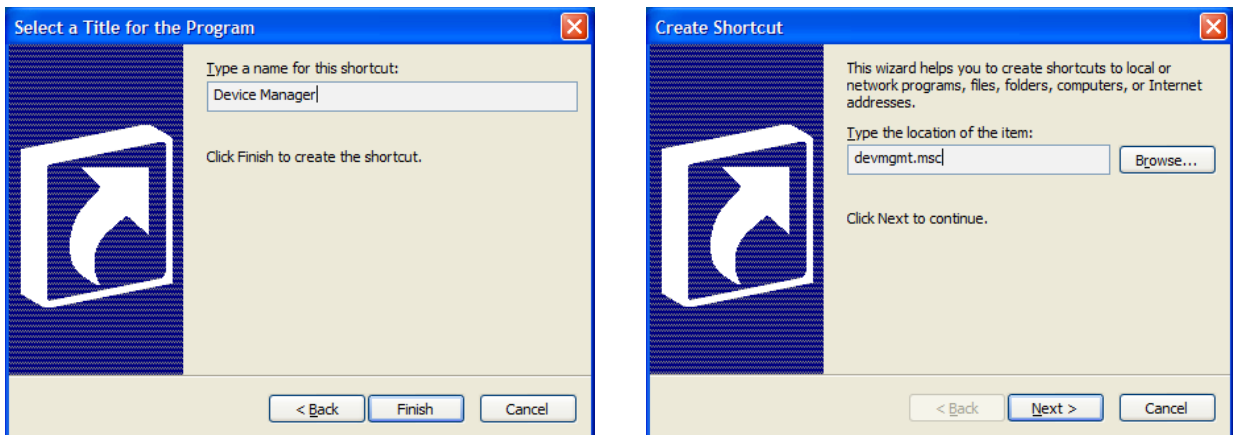

Figure 8 : Creating a Device Manager Shortcut



Imagenex Technology Corp.

IMAGENEX MODEL 882A

MULTI-FREQUENCY SCANNING DIGITAL SONAR HEAD
Imager

SERIAL INTERFACE SPECIFICATION

Version 2.0

Document Number	425-054	
Revision	Date	Description
0A	March 31, 2014	Taken and modified from 425051-02 (881AGS)
0B	September 16, 2014	Added Gyro Timeout
0C	February 11, 2015	Added Auto Bias Mode, firmware version 1

Specifications subject to change

OVERVIEW

The Model 882A uses the same command structure as the 881A-GS sonar, but with some restrictions.

The Model 882A Digital Sonar Head communicates over a serial communications link. To receive echo data, a command program must interrogate the sonar head by sending a Switch Data Command. When the Switch Data command is accepted, the sonar head transmits, receives and sends its return data back to the command program.



New since original 881A



Modified position or content from original 881A

SWITCH DATA COMMAND

The head accepts up to 40 bytes of switch data from the serial interface and must see the switch data header (2 bytes: **0xFE** and **0x44** HEX) in order to process the switches. The head will stop accepting switch data when it sees the termination byte (**0xFD** HEX), or 41 bytes (whichever comes first). The termination byte must be present for the head to process the switches.

Note: the Termination Byte is the only switch value allowed to have a value of 0xFD. All other switches should be set higher or lower than 0xFD (253 Decimal) so they are not interpreted as a termination byte!

Byte	Description									
0-9	0xFE	0x22	Head ID	Range	<i>Reserved 0</i>	Rev/ Hold	Master/ Slave	Reserved 0	Start Gain	LOGF
10-19	Absorption	Train Angle	Sector Width	Step Size	Pulse Length	Profile MinRange	<i>Reserved 0</i>	<i>Reserved 0</i>	<i>Reserved 0</i>	Data Points
20-29	Data Bits	Up Baud	Profile	Calibrate	Switch Delay	Frequency	Sensor Cmd LO	Sensor Cmd HI	Latitude LO	Latitude HI
30-39	<i>Gyro Biasing</i>	<i>Reserved 0</i>	<i>Reserved 0</i>	<i>Reserved 0</i>	<i>Reserved 0</i>	<i>Reserved 0</i>	<i>Reserved 0</i>	<i>Reserved 0</i>	<i>Reserved 0</i>	Term. 0xFD



Table 1: Model 881A-GS Switch Data Command To Sonar Head

BYTE DESCRIPTIONS

Note: All Byte values are shown in decimal unless noted with a '0x' (hexadecimal) prefix.

- Byte 0 **Switch Data Header (1st Byte)**
Always **0xFE** (254 decimal)
- Byte 1 **Switch Data Header (2nd Byte)**
Always **0x22** (34 decimal)
- Byte 2 **Head ID**
Normally 0x10
- Byte 3 **Range**
1, 2, 3, 4, 5, 10, 20, 30, 40, 50, 60, 80, 100 Meters
- Byte 4 **Reserved**
Always 0

Byte 5	<p>Rev / Hold</p> <p>Bit 0 - 1 = Hold (or pause) Head, 0 = Resume</p> <p>Bit 1 - 0</p> <p>Bit 2 - 0</p> <p>Bit 3 - 0</p> <p>Bit 4 - 0</p> <p>Bit 5 - 0</p> <p>Bit 6 - 1 = Reverse Step Direction, 0 = Normal Operation</p> <p>Bit 7 - 0</p>
Byte 6	<p>Master / Slave</p> <p>The sonar head can be operated as a master or as a slave. The default mode on power-up is Slave mode (Bit 6 = 1). Slave mode allows the user to command the head to transmit and send its return data at any given time.</p> <p>Bit 0 - 1 = Transmit if Bit 6 = 1 (Slave Mode)</p> <p>Bit 1 - 1 = Send Data if Bit 6 = 1 (Slave Mode)</p> <p>Bit 2 - 0</p> <p>Bit 3 - 0</p> <p>Bit 4 - 0</p> <p>Bit 5 - 0</p> <p>Bit 6 - 0 = Master, 1 = Slave</p> <p>Bit 7 - 0</p>
Byte 7	<p>Reserved</p> <p>Always 0</p>
Byte 8	<p>Start Gain</p> <p>0 to 40dB in 1dB increments</p>
Byte 9	<p>LOGF</p> <p>0 = 10dB</p> <p>1 = 20dB</p> <p>2 = 30dB</p> <p>3 = 40dB</p>
Byte 10	<p>Absorption</p> <p>0 to 255 = 0.00dB/m to 2.55dB/m</p> <p>Byte 10 = $\text{absorption_in_dB_per_m} * 100$</p> <p>Do not use a value of 253!</p>
Byte 11	<p>Train Angle</p> <p>0 to 120 (-180 Deg to +180 Deg = 360 Deg Total) in 3 Degree steps.</p> <p>Byte 11 = $(\text{train_angle_in_degrees} + 180)/3$</p> <p>i.e.</p> <p>0 = -180 Degrees</p> <p>30 = -90 Degrees</p> <p>60 = 0 Degrees</p> <p>90 = +90 Degrees</p> <p>120 = +180 Degrees</p>
Byte 12	<p>Sector Width</p> <p>0 to 120 (0 Deg to 360 Deg) in 3 Degree steps</p> <p>Byte 12 = $\text{sector_width_in_degrees}/3$</p> <p>i.e.</p> <p>0 = 0 Degrees</p> <p>30 = 90 Degrees</p> <p>60 = 180 Degrees</p> <p>120 = 360 Degrees</p>

- Byte 13 **Step Size**
 0 to 8 in 0.3 Degree increments
 i.e.
 0 = No Step
 1 = 0.3 Degrees/Step
 2 = 0.6 Degrees/Step
 3 = 0.9 Degrees/Step
 4 = 1.2 Degrees/Step
 8 = 2.4 Degrees/Step
- Byte 14 **Pulse Length**
 Length of acoustic transmit pulse.
 1-100 → 10 to 1000 μsec in 10 μsec increments
 Byte 14 = pulse_length_in_microseconds / 10
- Byte 15 **Profile Minimum Range**
 Minimum range for profile point digitization
 0 – 250 □ 0 to 25 meters in 0.1 meter increments
 Byte 15 = min range in meters * 10
- Byte 16 **Reserved**
 Always 0
- Byte 17 **Reserved**
 Always 0
- Byte 18 **Reserved**
 Always 0
- Byte 19 **Data Points**
 50 - 500 data points are returned by the head
 The return data will have an ASCII '**INB**' header. 
- Byte 20 **Data Bits**
 Resolution (number of data bits) of the returned echo data 
 8 - Data width = 8 Bits, 1 data point per byte
- Byte 21 **Up Baud**
****** NOTE: THIS FEATURE IS NOT YET AVAILABLE ******

 The head receives switch data at 115200 baud, but can transmit its return data at various baud rates. The Up Baud value sets the head to transmit at a new baud rate. The default Up Baud value on power-up is 115200 baud.

 0x0B - 9600 baud
 0x03 - 14400 baud
 0x0C - 19200 baud
 0x04 - 28800 baud
 0x02 - 38400 baud
 0x05 - 57600 baud
 0x06 - 115200 baud
- Byte 22 **Profile**
 0 = OFF
 1 = ON --> The return data will have an ASCII '**INC**' header.

Byte 23



Calibrate

0 = Normal Operation
 1 = Calibrate sonar head transducer (move to 0 degrees).

Byte 24

Switch Delay

The head can be commanded to pause (from 0 to 510 msec) before sending its return data to allow the commanding program enough time to setup for serial reception of the return data.
 0 to 255 in 2 msec increments
 Byte 24 = delay_in_milliseconds/2
 Do not use a value of 253!

Byte 25

Frequency

675kHz +/- 500kHz
 0 – 200 → 175kHz to 1175kHz in 5kHz increments
 Byte 25 = (frequency_in_khz - 675)/5 + 100

Bytes 26-27

Sensor Command

Byte 26								Byte 27							
7	6	5	4	3	2	1	0	7	6	5	4	3	2	1	0
LO								HI							



Bit	Function
0	Enable Gyro
1	Enable Pitch, Roll, Heading
2	Gyro Set
3	Transducer = UP
4	ReBias Gyro
5	Start compass calibration
6	Stop compass calibration
7	Always 0
8	Calibrate Pitch / Roll
9	Store Latitude
10	Gyro Set Target Location
11	Motion Bias Enable
12	<i>Reserved</i>
13	<i>Reserved</i>
14	<i>Reserved</i>
15	Always 0

Bytes 28-29

Latitude

Current Latitude of Sonar Location



Byte 28								Byte 29							
7	6	5	4	3	2	1	0	7	6	5	4	3	2	1	0
Latitude (LO)								Latitude (HI)							

Latitude High Byte = (Byte 29 & 0x7E)>>1

Latitude Low Byte = [((Byte 29 & 0x01)<<7) | (Byte 28 & 0x7F)]

Latitude = (Latitude High Byte<<8) | Latitude Low Byte

Bits 0-6 = Latitude in Degrees = 0 -> 90

Bit 7 = 0 -> North

Bit 7 = 1 -> South

ex.

+90° = byte 18 = 00, byte 19 = 0x5A

-90° = byte 18 = 01, byte 19 = 0x5A

Byte 30

Gyro Biasing Delay

1 – 252 → 1sec to 252 seconds

Byte 31

Reserved

Always 0

Byte 32

Reserved

Always 0

Byte 33

Reserved

Always 0

Byte 34

Reserved

Always 0

Byte 35

Reserved

Always 0

Byte 36

Reserved

Always 0

Byte 37

Reserved

Always 0

Byte 38

Reserved

Always 0

Byte 39

Termination Byte

The head will stop looking for Switch Data when it sees this byte.

Always 0xFD (253 decimal)

SONAR RETURN DATA

Every shot, the head returns a 32 Byte header, up to 500 points of echo data (depending on the Switch Data command that was sent) and a terminating byte value of 0xFC. The **total number of bytes (N)** returned will be 33, 161, 285 or 533.

Byte #	Description									
0-9	ASCII 'I'	ASCII 'N'	ASCII 'B', 'C'	Head ID	Serial Status	Xdcr Head Pos (LO)	Xdcr Head Pos (HI)	Range	Prof Rng (LO)	Prof Rng (HI)
10-19	Data Bytes (LO)	Data Bytes (HI)	Sonar Head Pos (LO)	Sonar Head Pos (HI)	Pitch (LO)	Pitch (HI)	Roll (LO)	Roll (HI)	Heading (LO)	Heading (HI)
20-29	<i>Firmware</i>	Gyro Heading (LO)	Gyro Heading (HI)	<i>Reserved</i> 0	<i>Reserved</i> 0	<i>Reserved</i> 0	<i>Reserved</i> 0	<i>Reserved</i> 0	<i>Reserved</i> 0	<i>Reserved</i> 0
30-(N-2)	<i>Reserved</i> 0	<i>Reserved</i> 0	<i>Echo Data</i> 0, 128, 252, 500 Data Bytes							
N-1	0xFC									

Table 2: Model 881A-GS Sonar Head Return Data

BYTE DESCRIPTIONS

Note: All Byte values are shown in decimal unless noted with a '0x' prefix.
N = total number of return bytes

Byte 0 - 2

Imagenex Return Data Header

ASCII 'INA', 'INB' or 'INC'

'I' = 0x49, 'N' = 0x4E, 'A' = 0x41, 'B' = 0x42, 'C' = 0x43



ASCII 'INA'

In response to a Switch Data Command with Data Points = 25

If Data Bits was set to 4: N = 161, (128 Data Bytes, 256 Points, 32 Byte Header)

If Data Bits was set to 8: N = 285, (252 Data Bytes, 252 Points, 32 Byte Header)

If Data Bits was set to 16: N = 533, (500 Data Bytes, 250 Points, 32 Byte Header)

ASCII 'INB'

In response to a Switch Data Command with Data Points = 50

If Data Bits was set to 4: N = 285, (252 Data Bytes, 504 Points, 32 Byte Header)

If Data Bits was set to 8: N = 533, (500 Data Bytes, 500 Points, 32 Byte Header)

If Data Bits was set to 16: N = 533, (500 Data Bytes, 250 Points, 32 Byte Header)

ASCII 'INC'

In response to a Switch Data Command with Profile = ON

N = 33, (0 Data Bytes, 0 Points, 32 Byte Header)

Byte 3

Head ID

16 Head ID's allowed: 0x10 to 0x1F

Byte 4

Serial Status

Bit 0 - 0

Bit 1 - 0

Bit 2 - 1 => Auto Bias Adjustment has occurred

Bit 3 - 1 => Gyro / PRH Error

Bit 4 - 1 => Gyro Calibrating

Bit 5 - 1 => Compass Calibrating

Bit 6 - 1 => Switches Accepted

Bit 7 - 1 => Character Overrun



Byte 5 - 6

Transducer Head Position

Byte 5								Byte 6							
7	6	5	4	3	2	1	0	7	6	5	4	3	2	1	0
0								0 D							
Head Pos (LO)								Head Pos (HI) L							

Head Pos (LO), Head Pos (HI), Step Direction (D)
 Head Pos High Byte = (Byte 6 & 0x3E)>>1
 Head Pos Low Byte = [((Byte 6 & 0x01)<<7) | (Byte 5 & 0x7F)]
 Head Position = (Head Pos High Byte<<8) | Head Pos Low Byte

Head Position = 0 to 1200 (-180 to +180 Degrees) in 0.3 Degree steps
 0 = -180 Degrees
 300 = -90 Degrees
 600 = 0 Degrees (Center Position)
 900 = +90 Degrees
 1200 = +180 Degrees

Example angle calculation:
 Angle = 0.3 * (Head Pos - 600)
 Head Pos = 900
 Angle = 0.3 * (900 - 600)
 Angle = +90 Degrees

Step Direction = (Byte 6 & 0x40)>>6
 0 = counter-clockwise
 1 = clockwise

Byte 7

Range

Sonar Head Range: 1 to 200 Meters

Byte 8 - 9

Profile Range (*Sample units are based on a sound velocity of 1500m/s*)

First digitized range value above threshold in sample units
 Prof Rng (LO), Prof Rng (HI)

Byte 8								Byte 9							
7	6	5	4	3	2	1	0	7	6	5	4	3	2	1	0
0								0							
Prof Rng (LO)								Prof Rng (HI) L							

Prof Rng High Byte = (Byte 9 & 0x7E)>>1
 Prof Rng Low Byte = [((Byte 9 & 0x01)<<7) | (Byte 8 & 0x7F)]
 Profile Range = (Prof Rng High Byte<<8) | Prof Rng Low Byte

For ranges < 5m, one sample unit = 2mm
 For ranges >= 5m, one sample unit = 10mm

Byte 10 - 11

Data Bytes

Byte 10								Byte 11							
7	6	5	4	3	2	1	0	7	6	5	4	3	2	1	0
0								0							
Data Bytes (LO)								Data Bytes (HI)							

Data Bytes High Byte = (Byte 11 & 0x7E)>>1
 Data Bytes Low Byte = [((Byte 11 & 0x01)<<7) | (Byte 10 & 0x7F)]
 Data Bytes = (Data Bytes High Byte<<8) | Data Bytes Low Byte

Bytes 12 - 13

Sonar Position

Angular position of the physical unit



Byte 12								Byte 13							
7	6	5	4	3	2	1	0	7	6	5	4	3	2	1	0
0								0							
Sonar Pos (LO)								Sonar Pos (HI)							

Sonar Pos (LO), Sonar Pos (HI)
 Sonar Pos High Byte = (Byte 13 & 0x7E)>>1
 Sonar Pos Low Byte = [((Byte 13 & 0x01)<<7) | (Byte 12 & 0x7F)]
 Sonar Position = (Sonar Pos High Byte<<8) | Sonar Pos Low Byte

Sonar Position = 0 to 1200 (-180 to +180 Degrees) in 0.3 Degree steps
 0 = -180 Degrees
 300 = -90 Degrees
 600 = 0 Degrees (Centre Position)
 900 = +90 Degrees
 1200 = +180 Degrees

Example angle calculation:
 Angle = 0.3 * (Head Pos - 600)
 Sonar Pos = 900
 Angle = 0.3 * (900 - 600)
 Angle = +90 Degrees

Bytes 14 - 15

Pitch



Byte 14								Byte 15							
7	6	5	4	3	2	1	0	7	6	5	4	3	2	1	0
0								0							
Pitch (LO)								Pitch (HI)							

Pitch High Byte = (Byte 15 & 0x7E)>>1
 Pitch Low Byte = [((Byte 15 & 0x01)<<7) | (Byte 14 & 0x7F)]
 Pitch = (Pitch High Byte<<8) | Pitch Low Byte

if Byte 15 - Bit 6 = 0:
 Pitch = Pitch * 360/16384 in degrees

if Byte 15 - Bit 6 = 1:
 Pitch = [Pitch - 16384] * 360/16384 in degrees

Byte 16 - 17 **Roll**



Byte 16								Byte 17								
7	6	5	4	3	2	1	0	7	6	5	4	3	2	1	0	
0	Roll (LO)							0	Roll (HI)							L

Roll High Byte = (Byte 17 & 0x7E)>>1
 Roll Low Byte = [((Byte 17 & 0x01)<<7) | (Byte 16 & 0x7F)]
 Roll = (Roll High Byte<<8) | Roll Low Byte

if Byte 17 - Bit 6 = 0:
 Roll = Roll * 360/16384 in degrees

if Byte 17 - Bit 6 = 1:
 Roll = [Roll - 16384] * 360/16384 in degrees

Byte 18 - 19 **Magnetic Heading**



Byte 18								Byte 19								
7	6	5	4	3	2	1	0	7	6	5	4	3	2	1	0	
0	Heading (LO)							0	Heading(HI)							L

Heading High Byte = (Byte 19 & 0x7E)>>1
 Heading Low Byte = [((Byte 19 & 0x01)<<7) | (Byte 18 & 0x7F)]
 Heading = [(Heading High Byte<<8) | Heading Low Byte] * 360/16384 in degrees
 0 = 0°
 3599 = 359.9°

Byte 20 **Firmware Version**
 0 = No Support for Automatic Gyro Biasing
 1 = Supports Automatic Gyro Biasing (and corrects Backwards heading)

Byte 21 - 22 **Gyro Heading**



Byte 21								Byte 22								
7	6	5	4	3	2	1	0	7	6	5	4	3	2	1	0	
0	Gyro Heading (LO)							0	Gyro Heading(HI)							L

Gyro High Byte = (Byte 22 & 0x7E)>>1
 Gyro Low Byte = [((Byte 22 & 0x01)<<7) | (Byte 21 & 0x7F)]
 Gyro Heading = [(Gyro High Byte<<8) | Gyro Low Byte] * 360/16384 in degrees
 0 = 0°
 3599 = 359.9°

Bytes 21-31 **Reserved**
 Always 0

Byte 32 **Start of Echo Data**
 (N-33) Bytes of data

If Header is ASCII 'INA':
 If Data Bits was set to 8: N = 285, (252 Data Bytes, 252 Points)
 1st Range Point = Byte 32
 2nd Range Point = Byte 33
 3rd Range Point = Byte 34
 4th Range Point = Byte 35
 etc. ...

If Header is ASCII '**INB**':

If Data Bits was set to 8: N = 533, (500 Data Bytes, 500 Points)

1st Range Point = Byte 32

2nd Range Point = Byte 33

3rd Range Point = Byte 34

4th Range Point = Byte 35

etc. ...

If Header is ASCII '**INC**':

There is no echo data and this byte is the termination

byte **0xFC** (N = 33). Use Profile Range Bytes from the Header.

Byte (N-2) **End of Echo Data**

Byte (N-1) **Termination Byte**
0xFC

IMAGENEX .81R RAW DATA FILE FORMAT

Version: 1.00

The .81R file format is used for the following gyro stabilized sonar heads:

Model 881A-GS
 Model 881L-GS
 Model 882A
 Model 882L

For each sonar ping, the following sections are written to the .81R file.

1. Ping Header - 1024 bytes
2. Device List - 1024 bytes
3. Raw Sonar Data - variable length
4. Internal Sensor Data
5. External Sensor Data
6. Future Expansion
7. Video Frame (if available)

1. Ping Header

- contains overhead information such as total number of bytes this ping, byte offsets and lengths of each section, ping timestamp, frequency, range, gain, etc.

2. Device List

- contains information on all connected devices (i.e. sonar head, GPS, MRU, Gyro/Heading, Sound Velocity sensor, etc.). Includes the device name, transfer speed, rep-rate, mounting offsets, mounting angles and data latency. Information in this section is not required and may be zero filled.

3. Raw Sonar Data

- contains Switch Data Command, Sonar Return Header and Raw Sonar Data

4. Internal Sensor Data

- contains values from optional sensors installed inside the sonar head (i.e. MRU)

5. External Sensor Data

- contains values from external sensors

6. Future Expansion

7. Video Frame

- if video is available from a connected USB frame grabber, the video frame is written to the file after the current ping data

Storage Format

All data is stored LSB first (least significant byte first or "Little-Endian" mode). The following conventions are used:

char	1-byte signed value	
BYTE	1-byte unsigned value	
ASCII	1-byte unsigned value	
short	2-byte signed value	(LSB,MSB)
WORD	2-byte unsigned value	(LSB,MSB)
int	4-byte signed value	(LSB,MDL,MDH,MSB)
DWORD	4-byte unsigned value	(LSB,MDL,MDH,MSB)
float	4-byte single precision floating point value	(LSB,MDL,MDH,MSB)

Section 1: **Ping Header** (length = 1024 bytes)

Byte	Description	Format
0	'8' - Ping Header byte 0	ASCII
1	'1' - Ping Header byte 1	ASCII
2	'R' - Ping Header byte 2	ASCII
3	Sonar Type 0 = Model 881L-GS 1 = Model 881A-GS 2 = Model 882L 3 = Model 882A	BYTE
4-7	Total Bytes This Ping (including Ping Header)	DWORD
8 - 9	.81R File Version 0 = 1.00 - initial release	WORD
10 - 27	Ping Timestamp - (18 bytes) DDMMYYYYHHMMSSmmmh 10-11: DD - day, 01-31 12-13: MM - month, 01-12 14-17: YYYY - year 18-19: HH - hours, 00-23 20-21: MM - minutes, 00-59 22-23: SS - seconds, 00-59 24-26: mmm - milliseconds, 000-999 27: NULL	ASCII
28	Reserved - always 0 (1 byte)	BYTE
29 - 58	Sonar Control Program Version Number (30 bytes) i.e. "Version 1.0.1.5 (19Sept14)" plus zero fill	ASCII
59 - 62	Byte offset to previous 81R Ping Header Note: all byte offsets are referenced to the beginning of the current Ping Header	DWORD
63	Status Byte 1 Bit 0: 1 = internal sensors available Bit 1: 1 = external sensors available Bit 2-7: Reserved	BYTE
64	Status Byte 2 - Reserved - always 0	BYTE
65	Status Byte 3 - Reserved - always 0	BYTE
66	Status Byte 4 - Reserved - always 0	BYTE
67	Status Byte 5 - Reserved - always 0	BYTE
68	Status Byte 6 - Reserved - always 0	BYTE
69	Status Byte 7 - Reserved - always 0	BYTE
70	Status Byte 8 - Reserved - always 0	BYTE
71 - 74	Reserved - always 0 (4 bytes)	BYTE
75 - 78	Ping Header length - 1024	DWORD
79 - 82	Byte offset to Device List - 1024	DWORD
83 - 86	Device List length - 1024	DWORD
87 - 90	Byte offset to Raw Sonar Data - 2048	DWORD
91 - 94	Raw Sonar Data length - variable	DWORD

95 - 98	Byte offset to Internal Sensors (0 if not available)	DWORD
99 - 102	Internal Sensor length (0 if not available)	DWORD
103 - 106	Byte offset to External Sensors (0 if not available)	DWORD
107 - 110	External Sensor length (0 if not available)	DWORD
111 - 318	Reserved - always 0 (208 bytes)	BYTE
319	Transducer Up/Down, Display Mode Bits 0-2: 000 = North Up 001 = Heading Up 010 = Target Steering Bits 3-6: Reserved Bit 7: Transducer Up/Down 0 = Down, 1 = Up	BYTE
320	Start Gain (dB)	BYTE
321	Sector Width Command 0 to 120 = 0 to 360 Degrees in 3 degree increments	BYTE
322	Train Angle Command 0 to 119 = 0 to 357 Degrees in 3 degree increments	BYTE
323	Step Size Command 0 = No Step 1 = 0.3 Degrees (Slow) 2 = 0.6 Degrees (Medium) 3 = 0.9 Degrees (Fast) 4 = 1.2 Degrees (Faster) 8 = 2.4 Degrees (Fastest)	BYTE
324	Mode 0 = Sector 1 = Polar 2 = Sidescan	BYTE
325 - 328	Range Offset (meters)	float
329 - 332	Absorption (dB/meter)	float
333	Reserved - always 0	BYTE
334 - 337	Pulse Length (microseconds)	DWORD
338 - 341	Sound Velocity (meters/second)	float
342 - 345	Acoustic Transmit Frequency (Hz)	float
346 - 349	Sonar Ping Repetition Rate (seconds)	float
350 - 352	Reserved - always 0	BYTE
353 - 356	Samples per ping	DWORD
357 - 360	Sector Size (degrees)	float
361 - 364	Train Angle (degrees)	float
365 - 368	Step Size - Angle Increment (degrees)	float
369 - 372	Acoustic Range Setting (meters)	float
373 - 376	Range Resolution (meters)	float
377 - 380	Ping Number	DWORD
381	System Information Flag	BYTE
382	Gyro Status (0=Disabled, 1=Enabled)	BYTE
383 - 386	Mounting Angle Offset (-180 to +180 in decimal degrees)	float
387 - 390	Local Latitude (-90 South to +90 North in decimal degrees)	float
391 - 394	Compass Declination (-180 to +180 in decimal degrees)	float
395 - 1023	Reserved - always 0 (629 bytes)	BYTE

Section 2: **Device List** (length = 1024 bytes)

Note: information in this section is not required and may be zero filled.

Each connected device contains the following 64-byte structure:

Byte	Description	Format
0 - 15	Device Name (16 bytes) i.e. "881L-GS Sonar" plus zero fill	ASCII
16 - 19	Transfer Speed (bits per second)	DWORD
20 - 23	Repetition Rate (seconds)	float
24 - 27	Starboard mounting offset (meters, portside is negative)	float
28 - 31	Forward mounting offset (meters, aft is negative)	float
32 - 35	Vertical mounting offset (meters, up is negative)	float
36 - 39	Yaw - mounting offset (degrees, counter-clockwise is negative)	float
40 - 43	Pitch - mounting offset (degrees, nose down is negative)	float
44 - 47	Roll - mounting offset (degrees, portside roll is negative)	float
48 - 51	Latency (seconds)	float
52 - 63	Reserved - always 0 (12 bytes)	BYTE

Device 1 (Sonar Head):

- Byte 0 = Byte offset to Device List (from Ping Header, Bytes 79-82)
- note: sonar head transfer speed is 10 for 10Mbps or 100 for 100Mbps

Device 2 (GPS Antenna):

- Byte 0 = Byte offset to Device List + 64

Device 3 (MRU):

- Byte 0 = Byte offset to Device List + 128

Device 4 (Gyro/Heading):

- Byte 0 = Byte offset to Device List + 192

Section 3: Raw Sonar Data (length = Variable)

The Raw Sonar Data section contains the communications transfers to and from the sonar head for the current ping. The transfers consist of the Switch Data Command to the sonar head as well as the Sonar Return Header and Sonar Echo Data from the sonar head. The length of this section varies depending on the type of sonar head.

The following tables describe the total number of bytes stored for each sonar head type:

Sonar Type = Model 881L-GS

Ping Header Byte 3 = 0

1. Switch Data Command - 128 bytes
2. Sonar Return Header - 256 bytes
3. Sonar Echo Data - 500 bytes (IBX mode)
Total = 884 bytes

Byte Offset	Description	Length
0000 - 1023	Ping Header	1024
1023 - 2047	Device List	1024
2048 - 2175	Switch Data Command	128
2176 - 2431	Sonar Return Header	256
2432 - 2931	Sonar Echo Data	500

For IBX mode, the Sonar Echo Data starts at byte offset 2432 and consists of 500 range bins of 8-Bit (0-255) echo intensity values. Each range bin is (Range/500) in length. Range (in meters) is located in "Range" (Bytes 20-21) of the Sonar Return Header. Range bins assume a sound velocity of 1500m/s. The angular position of the ping echo is encoded in "Transducer Head Position" (Bytes 35-36) of the Sonar Return Header.

Please refer to document "**425-050-01 - 881L - GS Ethernet Specification.pdf**" for detailed information about the Sonar Return Data format for the Model 881L-GS sonar head.

Sonar Type = Model 881A-GS

Ping Header Byte 3 = 1

1. Switch Data Command - 40 bytes
2. Sonar Return Header - 32 bytes
3. Sonar Echo Data - 500 bytes (INB mode)
Total = 572 bytes

Byte Offset	Description	Length
0000 - 1023	Ping Header	1024
1023 - 2047	Device List	1024
2048 - 2087	Switch Data Command	40
2088 - 2119	Sonar Return Header	32
2120 - 2619	Sonar Echo Data	500

For INB mode, the Sonar Echo Data starts at byte offset 2120 and consists of 500 range bins of 7-Bit (0-127) echo intensity values. Each range bin is (Range/500) in length. Range (in meters) is located in "Range" (Byte 7) of the Sonar Return Header. Range bins assume a sound velocity of 1500m/s. The angular position of the ping echo is encoded in "Transducer Head Position" (Bytes 5-6) of the Sonar Return Header.

Please refer to document "**425-051-03 - 881A - gyro Serial Specification.pdf**" for detailed information about the Sonar Return Data format for the Model 881A-GS sonar head.

Sonar Type = Model 882L

Ping Header Byte 3 = 2

1. Switch Data Command - 128 bytes
2. Sonar Return Header - 256 bytes
3. Sonar Echo Data - 500 bytes (IBX mode)
Total = 884 bytes

Byte Offset	Description	Length
0000 - 1023	Ping Header	1024
1023 - 2047	Device List	1024
2048 - 2175	Switch Data Command	128
2176 - 2431	Sonar Return Header	256
2432 - 2931	Sonar Echo Data	500

For IBX mode, the Sonar Echo Data starts at byte offset 2432 and consists of 500 range bins of 8-Bit (0-255) echo intensity values. Each range bin is (Range/500) in length. Range (in meters) is located in "Range" (Bytes 20-21) of the Sonar Return Header. Range bins assume a sound velocity of 1500m/s. The angular position of the ping echo is encoded in "Transducer Head Position" (Bytes 35-36) of the Sonar Return Header.

Please refer to document "**425-xxx-xx - 882L - GS Ethernet Specification.pdf**" for detailed information about the Sonar Return Data format for the Model 882L sonar head.

Sonar Type = Model 882A

Ping Header Byte 3 = 3

1. Switch Data Command - 40 bytes
2. Sonar Return Header - 32 bytes
3. Sonar Echo Data - 500 bytes (INB mode)
Total = 572 bytes

Byte Offset	Description	Length
0000 - 1023	Ping Header	1024
1023 - 2047	Device List	1024
2048 - 2087	Switch Data Command	40
2088 - 2119	Sonar Return Header	32
2120 - 2619	Sonar Echo Data	500

For INB mode, the Sonar Echo Data starts at byte offset 2120 and consists of 500 range bins of 7-Bit (0-127) echo intensity values. Each range bin is (Range/500) in length. Range (in meters) is located in "Range" (Byte 7) of the Sonar Return Header. Range bins assume a sound velocity of 1500m/s. The angular position of the ping echo is encoded in "Transducer Head Position" (Bytes 5-6) of the Sonar Return Header.

Please refer to document "**425-054-0C - 882A - Serial Specification.pdf**" for detailed information about the Sonar Return Data format for the 882A sonar head.

Section 4: **Internal Sensor Data**

This section is reserved for future use.

Byte offset to Internal Sensors, (Ping Header, Bytes 95-98) = 0

Internal Sensor length, (Ping Header, Bytes 99-102) = 0

Section 5: **External Sensor Data**

This section is reserved for future use.

Byte offset to External Sensors, (Ping Header, Bytes 103-106) = 0

External Sensor length, (Ping Header, Bytes 107-110) = 0

Section 6: **Future Expansion**

This section is reserved for future use.

Section 7: **Video Frame** (length is variable)

Byte	Description	Format
	Bitmap Header	
0	'B' - Video Frame Header byte 0	ASCII
1	'M' - Video Frame Header byte 1	ASCII
2 - 5	Video Frame Filesize 14 + 40 + (ImageWidth x ImageHeight x 3) bytes	DWORD
6 - 7	Reserved1 - always 0	WORD
8 - 9	Reserved2 - always 0	WORD
10 - 13	Image Data Offset = 54	DWORD
	Bitmap Information Header	
14 - 17	HeaderSize = 40	DWORD
18 - 21	ImageWidth (in pixels)	DWORD
22 - 25	ImageHeight (in pixels)	DWORD
26 - 27	NumberOfImagePlanes = 1	WORD
28 - 29	BitsPerPixel = 24	WORD
30 - 33	CompressionMethod = 0	DWORD
34 - 37	SizeOfBitmap = (ImageWidth x ImageHeight x 3)	DWORD
38 - 41	HorzResolution = 0	DWORD
42 - 45	VertResolution = 0	DWORD
46 - 49	NumColorsUsed = 0	DWORD
50 - 53	NumSignificantColors = 0	DWORD
	24 Bit ImageData (stored as 3 bytes per pixel)	
54 - 57	Pixel 0 - Blue, Green, Red (lower-left corner of image)	BYTE
58 - 60	Pixel 1 - Blue, Green, Red	BYTE
.	.	.
.	.	.
Video Frame Filesize-3	Pixel N (ImageWidth x ImageHeight - 1) - Blue, Green, Red (upper-right corner of image)	BYTE

SUBCONN MCBH4M-SS-1/2"L THD

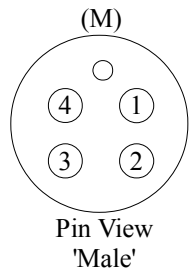

IMPULSE IE55 -1204-CCP

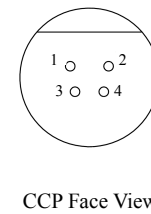

IMAGENEX TECHNOLOGY CORP.		
Title:	Model 882A - 881A Cable Adapter	
Document Number:	882-200-355	Rev 01
Date:	December 23, 2015	Sheet 1 of 1

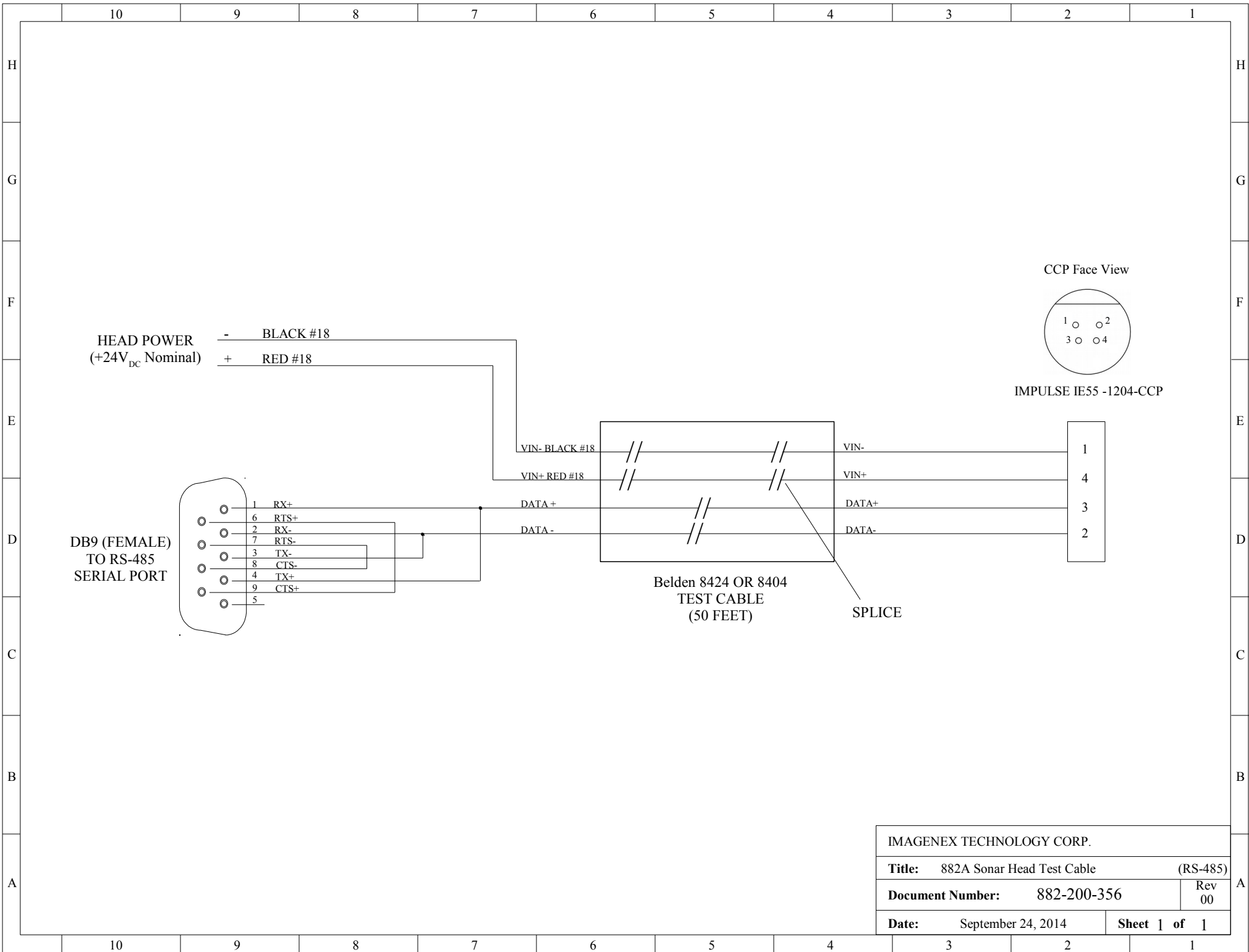

IMAGENEX TECHNOLOGY CORP.	
Title: 882A Sonar Head Test Cable	(RS-485)
Document Number: 882-200-356	Rev 00
Date: September 24, 2014	Sheet 1 of 1